

4.4 Laboratory Procedure / Summary Sheet

Group: _____ Names: _____

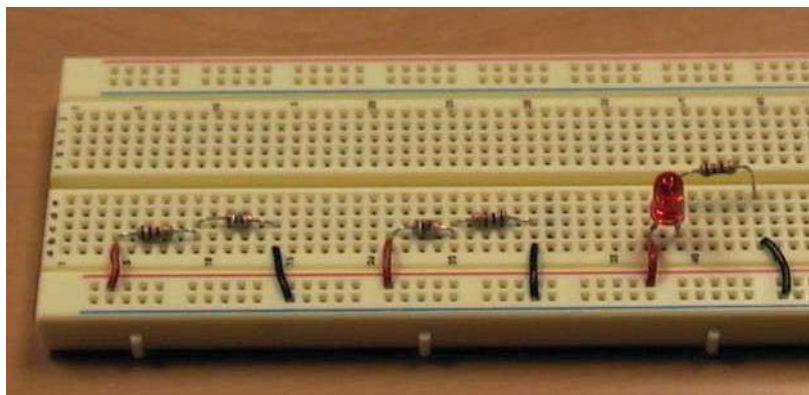

Figure 4.5 Circuits for Steps 1 and 3

- (1) Build each filter circuit shown below. For each, use the procedures outlined in the previous section to generate the frequency sweep response and to estimate the cutoff frequency. Also, make a rough sketch of the response.

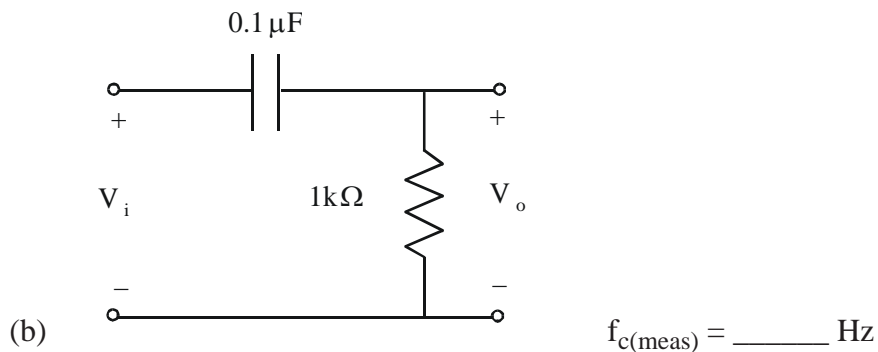
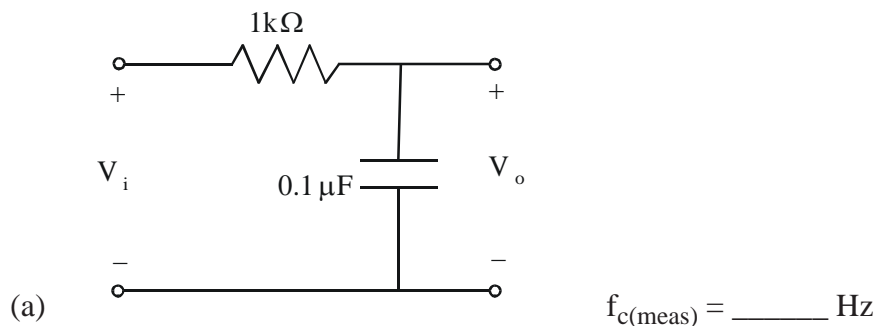

Figure 4.6 Filter Circuits

- (2) Examine the silicon diode and LED. Decide which lead is the anode and which is the cathode. As shown in the Figure 4.7, the anode lead on an LED is longer. If using the HP 34401A DMM, select the diode test function ($\rightarrow|$) and determine if the leads are identified properly. You will notice that the diode test does not work properly for the LED. This is because the LED voltage drop is larger than the expected range for a silicon diode (0.3 V to 0.8 V). However, you should see the LED light up when properly biased by the DMM. Write down the measured voltage drop across the silicon diode.

$V_{\text{diode}} = \text{_____ V}$

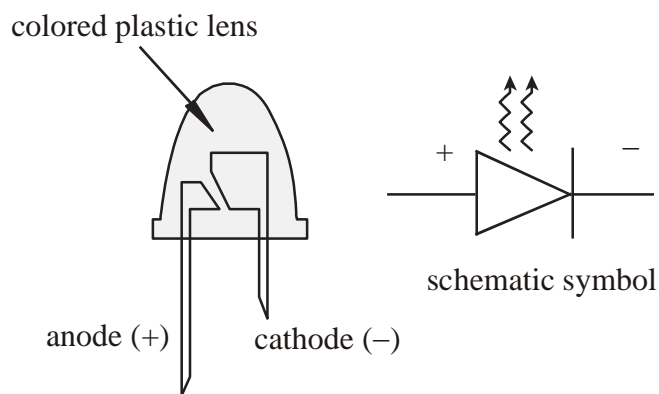

Figure 4.7 LED

- (3) Construct the circuit in Figure 4.8 for both the diode and the LED and record the indicated voltages. Make a sketch for each output voltage superimposed on the input for the signals labeled with an asterisk below.

V_i	V_D (diode)	V_o (diode)	V_D (LED)	V_o (LED)
+5 V				
-5 V				
$2 \sin(6\pi t)$	*	*	*	*

*: Sketch one cycle of the input voltage and the measured voltages (V_D and V_o) versus time. Use the axes provided below and provide appropriate scales and label each curve.

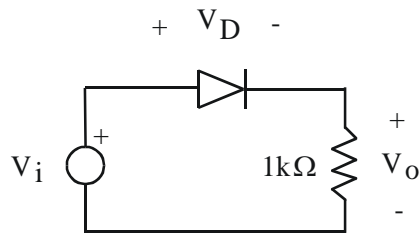
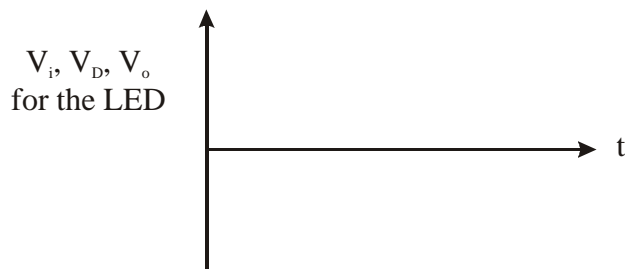
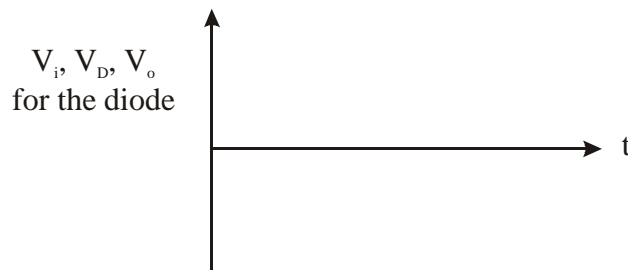

Figure 4.8 Diode/LED Circuit



LAB 4 QUESTIONS

Group: _____ Names: _____

(1) For the circuit in Step 1a:

what type of filter is this? _____

Also, calculate the theoretical cutoff frequency and the percent error in your measured value:

$\omega_{c(\text{meas})} =$ _____ $\omega_{c(\text{theor})} =$ _____ % error = _____

Remember that $\omega = 2\pi f$.

(2) For the circuit in Step 1b, derive expressions for the magnitude ratio of the frequency response and for the cutoff frequency (ω_c).

$\left| \frac{V_o}{V_i} \right| =$ _____ $\omega_c =$ _____

what type of filter is this? _____

Also, calculate the theoretical cutoff frequency and the percent error in your measured value:

$$\omega_{c(\text{meas})} = \text{_____} \quad \omega_{c(\text{theor})} = \text{_____} \quad \% \text{ error} = \text{_____}$$

- (3) In step 3, if the diode were removed and replaced in the opposite direction in the circuit, what effect would this have on the outputs for the sine wave input?