

Laboratory 1

Introduction - Resistor Codes, Breadboard, and Basic Measurements

Required Components:

- 3 1k Ω resistors

1.1 Introduction and Objectives

Welcome to the world of mechatronics. Your experiences in this laboratory will provide a solid foundation in instrumentation and modern electronics. The purpose of the first laboratory exercise is to familiarize you with the laboratory facilities and procedures, and with basic measurement techniques. The specific objectives are:

- Observe demonstrations of the instruments that you will use throughout the semester. These instruments include the oscilloscope, digital multimeter, power supply, and function generator.
- Learn how to construct basic electrical circuits using a breadboard.
- Learn how to properly take voltage and current measurements in circuits.
- Learn the resistor color code scheme necessary to read resistor values and tolerances.
- Learn about the types of capacitors and how to read their values.

1.2 Electrical Safety

Electrical voltages and currents can be dangerous if they occur at values that interfere with physiological functions. All of the laboratory exercises described in this manual are designed to use ac and dc voltages whose values are less than 15 V, values that will not cause perceptible shock via the skin. If working with voltages higher than these, especially line voltages (110 V_{rms} or 220 V_{rms}), one must be extremely careful to avoid shock or potentially lethal situations. We caution the user of household voltages and currents to carefully read the electrical safety precautions outlined in the textbook (see Section 2.10.1).

1.3 Resistor Color Codes

The most common electrical component found in almost every electrical circuit is a resistor. The type we will use in the Lab is the 1/4 watt axial-lead resistor. A resistor's value and tolerance are usually coded with four colored bands (*a, b, c, tol*) as illustrated in Figure 1.1. The colors used for bands are listed with their respective values in Table 1.1. A resistor's value and tolerance are expressed as

$$R = ab \times 10^c \pm \text{tol} \% \quad (1.1)$$

where the a band represents the tens digit, the b band represents the ones digit, the c band represents the power of 10, and the tol band represents the tolerance or uncertainty as a percentage of the coded resistance value. The set of standard values for the first two digits are: 10, 11, 12, 13, 14, 15, 16, 18, 20, 22, 24, 27, 30, 33, 36, 39, 43, 47, 51, 56, 62, 68, 75, 82, and 91.

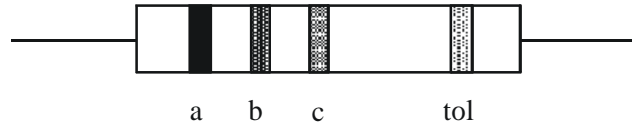

Figure 1.1 Wire lead resistor color bands

Table 1.1 Resistor color band codes

<i>a, b, and c</i> Bands		<i>tol</i> Band	
Color	Value	Color	Value
Black	0	Gold	±5%
Brown	1	Silver	±10%
Red	2	Nothing	±20%
Orange	3		
Yellow	4		
Green	5		
Blue	6		
Violet	7		
Gray	8		
White	9		

1.4 Reading Capacitor values

Most students learn to read resistor values quite easily. However, they often have more trouble picking out a specific capacitor. That's not their fault. They have trouble, as you will agree when you have finished reading this, because the capacitor manufacturers don't want them to be able to read cap values. ("Cap" is shorthand for "capacitor," as you probably know.) The cap markings have been designed by an intergalactic committee to be nearly unintelligible. With a few hints, however, you can learn to read cap markings, despite the manufacturers' efforts to prevent this. Some hints for various size capacitors follow.

Big Capacitors

Big Caps are usually the electrolytic type. These are easy to read, because there is room to print the value on the cap, including units. You need only have the common sense to assume that, for example, +500MF means 500 micro farads, with the plus indicating the positive end of the capacitor. Be careful to not take the capital M seriously. (Remember the SI system of units?)

All of these big caps are polarized. That means the capacitor's innards are not symmetrical, and that you may destroy the cap if you apply the wrong polarity to the terminals: the terminal marked + must be at least as positive as the other terminal. (Sometimes, violating this rule will form gas that makes the cap blow up; more often, the cap will short internally.)

Smaller Capacitors

As the caps get smaller, the difficulty in reading their markings gets steadily worse. Tantalum caps are silver colored cylinders. They are polarized: a + mark and a metal nipple mark the positive end. Their markings may say something like +4R7 μ . That also means pretty much what it says, if you know that the "R" marks the decimal place: it's a 4.7 μ F cap.

The same cap could also be marked +475K. Here you encounter your first challenge, but also the first appearance of an orderly scheme for labeling caps, a scheme that would be helpful if it were used more widely. The challenge is to resist the plausible assumption that "K" means "kilo." It does not; it is not a unit marking, but a tolerance notation (it means $\pm 10\%$). (Wasn't that nasty of the labelers to choose "K?" Guess what's another favorite letter for tolerance. That's right: M. Pretty mean!) The orderly labeling here mimics the resistor codes: 475 means 47 times ten to the fifth power. But what are the Units? 10^5 what? 10^5 of something small. You will meet this dilemma repeatedly, and you must resolve it by relying on the following intuitive observations:

1. The only units commonly used in this country are

microfarads: 10^{-6} Farad

picofarads: 10^{-12} Farad

(you should, therefore, avoid using "mF" and "nF" yourself.)

A Farad is a humongous unit. The biggest cap you will use in this course is 500 μ F. It is physically large (we do keep 1F caps around, but only for our freak show). Thus, if you find a small cap labeled "470," you know it is 470pF.

2. A picofarad is a tiny unit. You will not see a cap as small as 1 pF in this course. So, if you find a cap appearing to claim that it is a fraction of some unprinted unit – say, ".01" – the unit is μ F: ".01" means 0.01 μ F.
3. A picofarad is not just a bit smaller than a microfarad. A pF is not 10^{-9} F (10^{-3} μ F); instead, it is 10^{-12} F: a million times smaller than a microfarad!

So, we conclude, a cap labeled "475" must be 4.7×10^6 (47×10^5) picofarads. That, you will recognize, is a roundabout way to say 4.7×10^{-6} F or 4.7 μ F.

We knew that this was the answer, before we started this last decoding effort. This way of labeling is quite roundabout, but at least it is unambiguous. It would be nice to see it used more widely. You will see another example of this exponential labeling in the case of the CK05 ceramic caps, below.

Mylar caps are yellow cylinders, that are rather clearly marked. ".01M" is just 0.01 μF , of course; and ".1 MFD" is not a tenth of a megafarad. You can orient them at random in your circuits. Because they are fabricated as long coils of metal foil (separated by a thin dielectric - the "mylar" that gives them their name), mylar caps must betray their function at very high frequencies: that is, they begin to behave as inductors instead, blocking the very high frequencies they ought to pass. Ceramics (below) do better in this respect, although they are very poor in other characteristics.

Ceramic caps are little orange pancakes. Because of this shape (in contrast to the coil format hidden within the tubular shape of mylars) they act like capacitors even at high frequencies. The trick, in reading these, is to reject the markings that should not be interpreted as units. For example, a ceramic disk cap labeled by "Z5U .02M 1kV" is a 0.02 μF cap with a maximum voltage rating of 1kV. The M is a tolerance marking, in this case (see below), $\pm 20\%$.

CK05 caps are little boxes, with their leads 0.2" apart so they can be easily inserted in protoboards (AKA perf boards or vector boards) or PC boards. Therefore, they are common and useful. An example marking is 101K. This is the neat resistor-like marking. This one is 100 pF (10×10^1 pF).

Tolerance Codes

Finally, just to be thorough, and because this information is hard to come by, let's list all the tolerance codes. These apply to both capacitors and resistors; the tight tolerances are relevant only to resistors; the strangely asymmetric tolerance is used only for capacitors.

Tolerance Code	Meaning
Z	+80%, -20%
M	$\pm 20\%$
K	$\pm 10\%$
J	$\pm 5\%$
G	$\pm 2\%$
F	$\pm 1\%$
D	$\pm 0.5\%$
C	$\pm 0.25\%$
B	$\pm 0.1\%$
A	± 0.005
Z	± 0.025 (precision resistors; context will show the asymmetric cap tolerance "Z" makes no sense here)
N	$\pm 0.02\%$

1.5 The Breadboard

A breadboard is a convenient device for prototyping electrical and electronic circuits in a form that can be easily tested and changed. Figure 1.2 illustrates a typical breadboard layout consisting of a rectangular matrix of insertion points spaced 0.1 in apart. As shown in the figure, each column a through e, and f through j, is internally connected, respectively. The + and - rows that lie along the top and bottom edges of the breadboard are also internally connected to provide convenient DC voltage and ground busses for connecting to specific insertion points. As illustrated in the figure, integrated circuits (IC) are usually inserted across the gap between columns a through e, and f through j. A 14-pin dual in-line package (DIP) IC is shown here. When the IC is placed across the gap, each pin of the IC is connected to a separate numbered column, making it easy to make connections to and from the IC. The figure also shows an example of how to construct a simple resistor circuit. The schematic for this circuit is shown in Figure 1.3. Figure 1.4 shows an example of a wired breadboard including resistors, an integrated circuit, and a push-button switch. Generally, it is a good practice to keep wires and component leads as short as possible to keep everything neat and to prevent possible shorting between components; however, since you will be using your kit components throughout the semester, you should leave them untrimmed. Shorter leads can sometimes be limiting if you need to re-use the components in other circuits in the future.

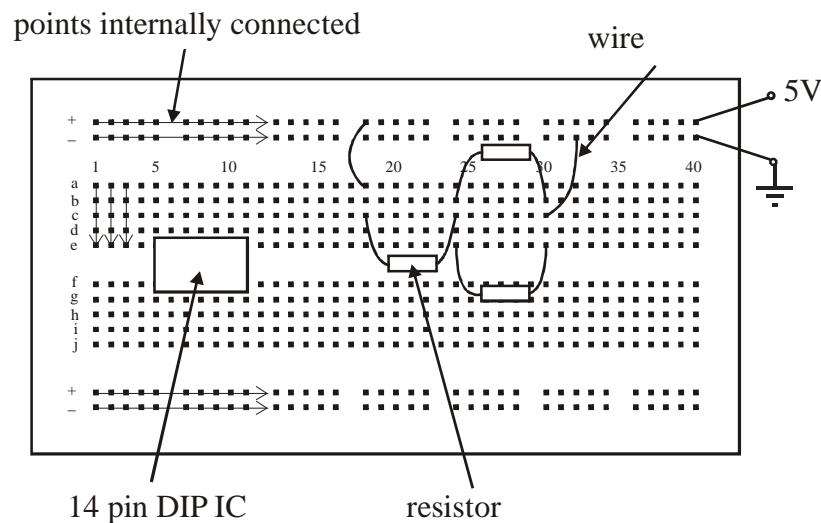

Figure 1.2 Breadboard

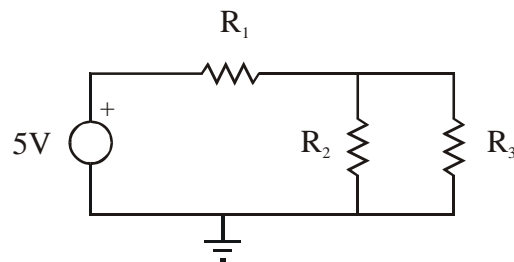

Figure 1.3 Example resistor circuit schematic

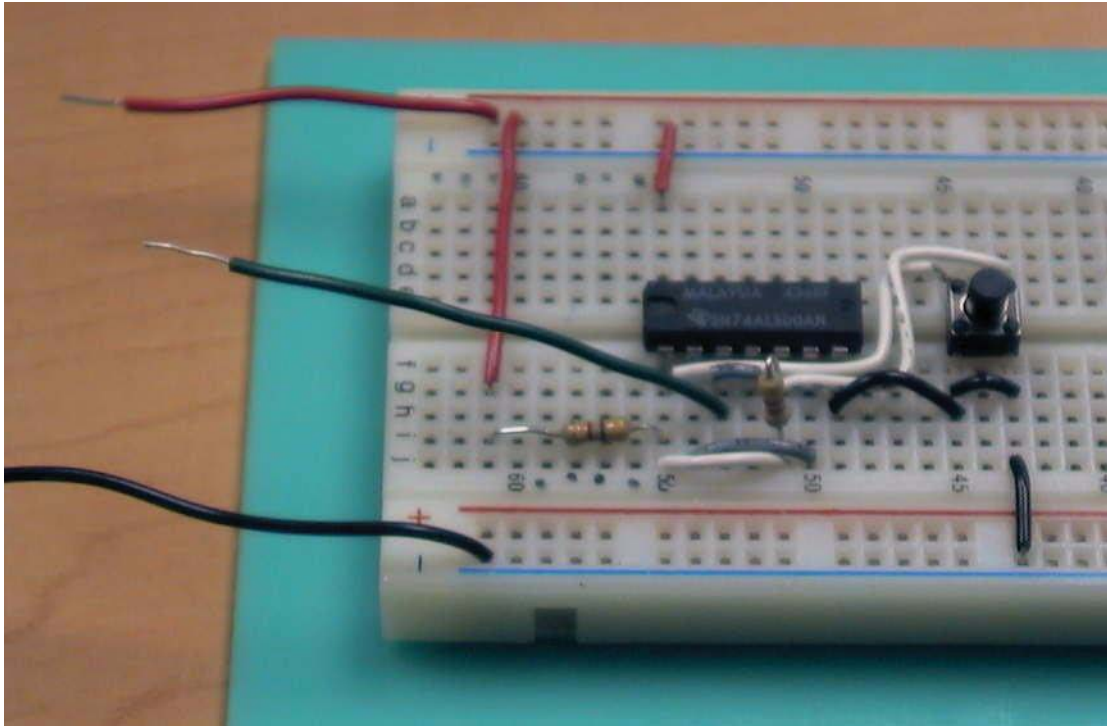

Figure 1.4 Example Breadboard Circuit

It is very important that you know how to take voltage and current measurements, especially when prototyping a circuit. As shown in Figure 1.5, when taking a voltage measurement, the leads of the voltmeter are simply placed across the element for which you desire the voltage. However, as shown in Figure 1.6, **when taking a current measurement through an element, the ammeter must be connected in series with the element.** This requires physically altering the circuit to insert the ammeter in series. For the example in the figure, the top lead of resistor R_3 must be removed from the breadboard to make the connection through the ammeter.

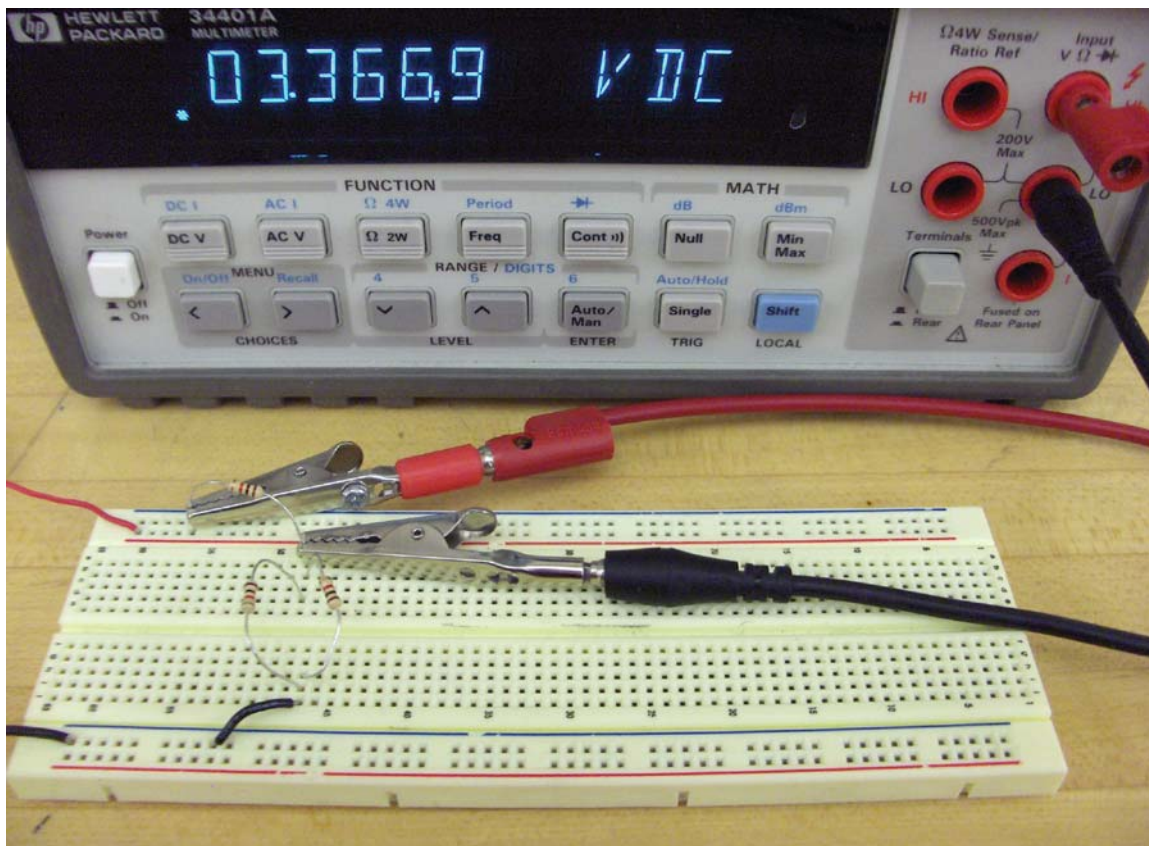
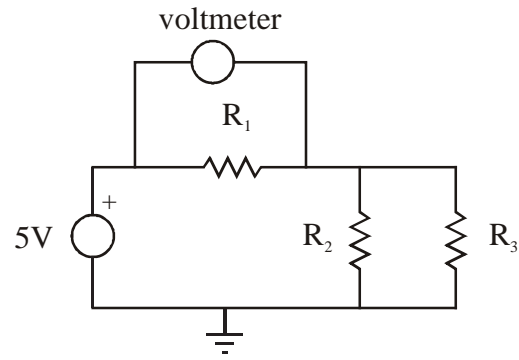

Figure 1.5 Voltage measurement across R_1

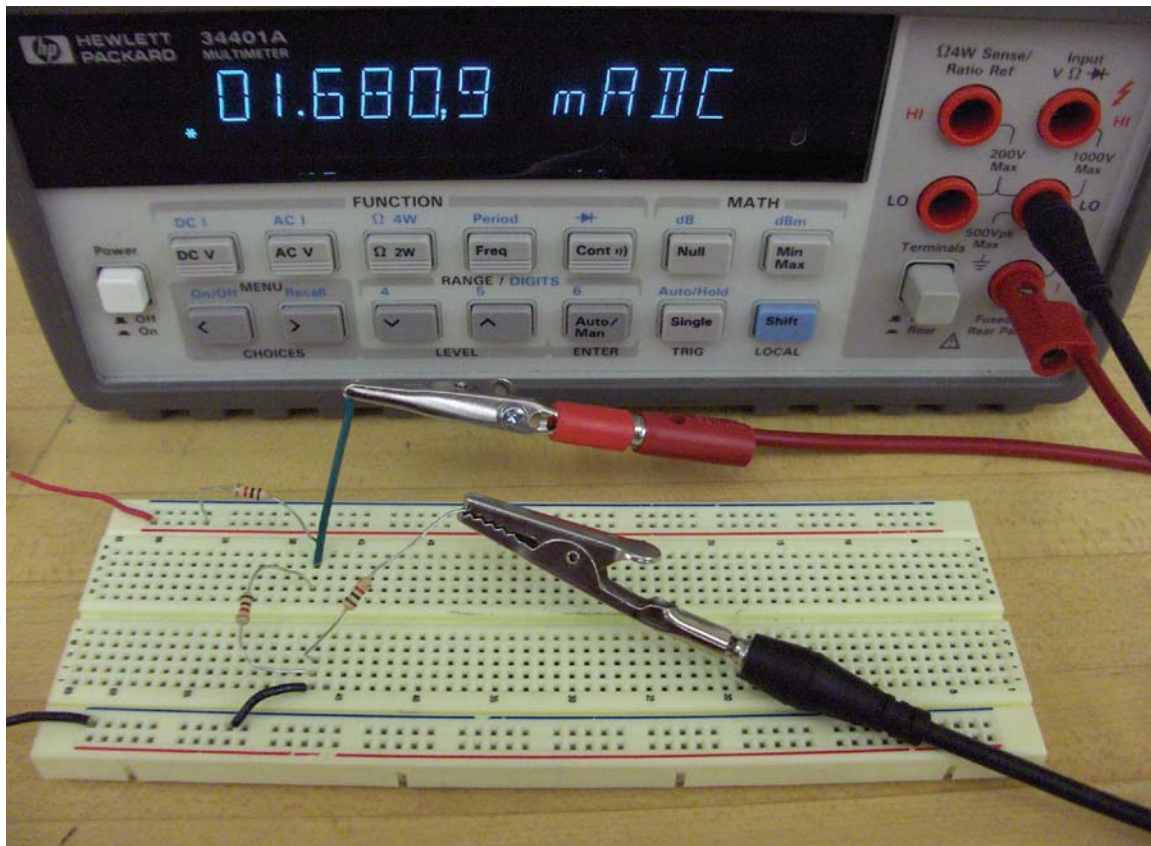
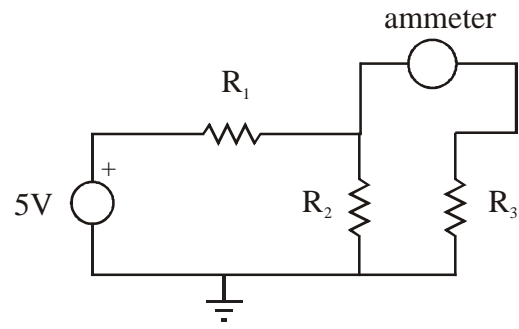

Figure 1.6 Current measurement through R_3

1.6 Laboratory Procedure / Summary Sheet

Group: _____ Names: _____

(1) For a 1kΩ resistor, what are the color band colors and associated band values?

band	color	value
a		
b		
c		
tol		

What is the expected nominal resistance and tolerance (in Ohms)?

R = _____ Ω ± _____ Ω (not %)

R_{min} = _____ R_{max} = _____

(2) Select three 1kΩ resistors, and measure the resistance of each using the digital multimeter and compare the values with the specified value.

Resistor	Measured Value (Ω)	% Error
R ₁		
R ₂		
R ₃		

- (3) Build the circuit shown in Figure 1.7 with the three given resistors on the breadboard. Note that R_1 is in series with the parallel combination of R_2 and R_3 .

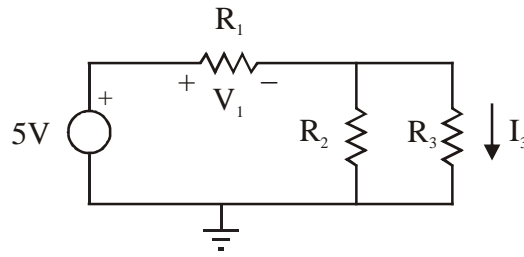

Figure 1.7 Resistor circuit schematic

- (4) Calculate the values for the voltage drop across R_1 and the current through R_3 assuming that all three resistors have equal value $1k\Omega$. Refer to the text book and Section 2.2 in the next laboratory exercise for background theory. Use the digital multimeter to measure the actual voltage and current values. As shown in Figure 1.5, to measure current with the multimeter, you must put the meter in series with the element of interest. So to measure I_3 , you must pull out the top end of R_3 and attach the meter probes between the exposed end of R_3 and either of the connected ends of R_1 and R_2 (as shown in Figure 1.5). **Be very careful when using the ammeter feature of the multimeter. If you don't place the meter in series with an element, and you put the leads across an element instead, you can burn out the meter's fuse and/or damage the device.**

	calculated	measured
V_1		
I_3		

If your measured values differ from your calculated values, provide possible explanations for the differences.