

Chapter 1 Summary

Introduction to Mechatronics and Measurement Systems

mechatronics: rapidly developing, interdisciplinary field of engineering dealing with the design of products whose function relies on the integration of mechanical and electronic components coordinated by a control architecture.

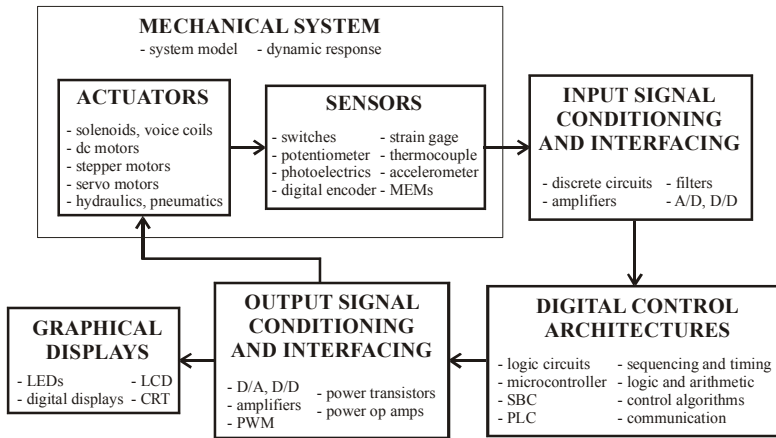

Mechatronic system components



Elements of a measurement system